

Subwoofer placement

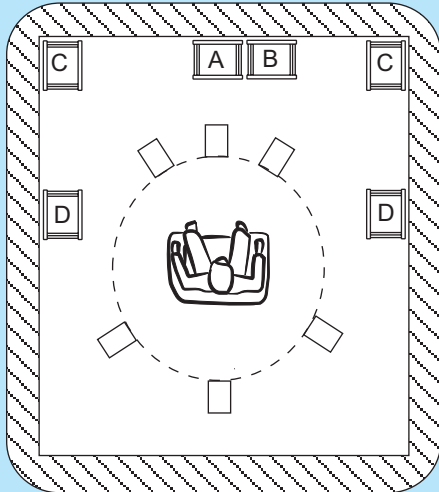

Note:

- 1) Positions A and B are recommended.
- 2) Position C causes a significant bass boost and may cause asymmetrical spatial imaging one subwoofer is used.
- 3) Positions C and D may also work, but may cause loss of LF when off room center axis.

Suggested Tone Control settings

<p>Input sensitivity</p>	<p>Bass Roll-Off</p>	<p>Position A, B and D -2 dB</p>
<p>Input sensitivity</p>	<p>Bass Roll-Off</p>	<p>Position C -4 dB</p>

Distance from front wall

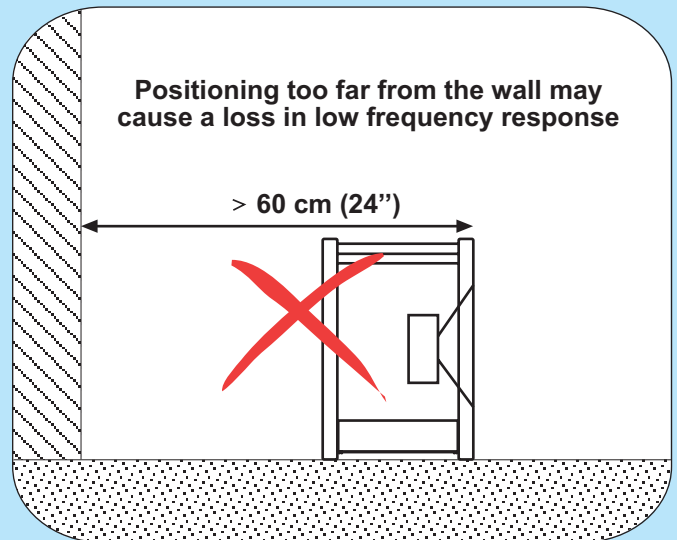
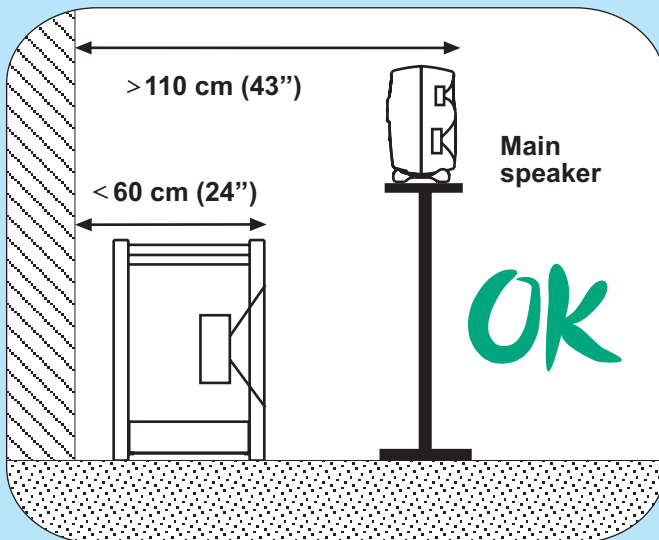

Aligning the subwoofer

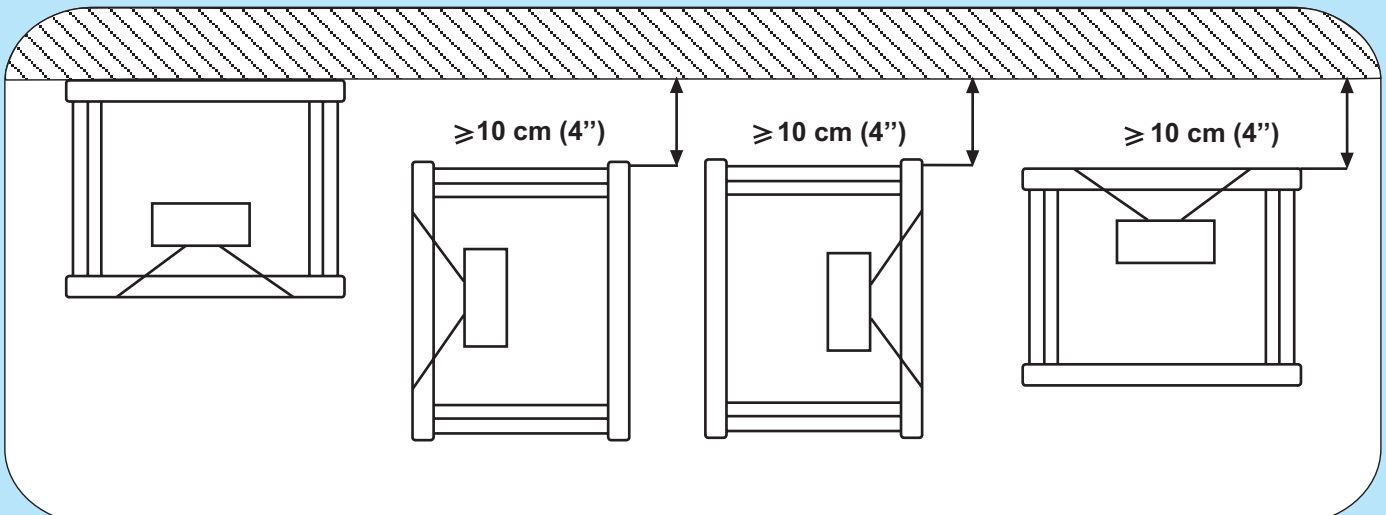

5.1 Connection and Wiring

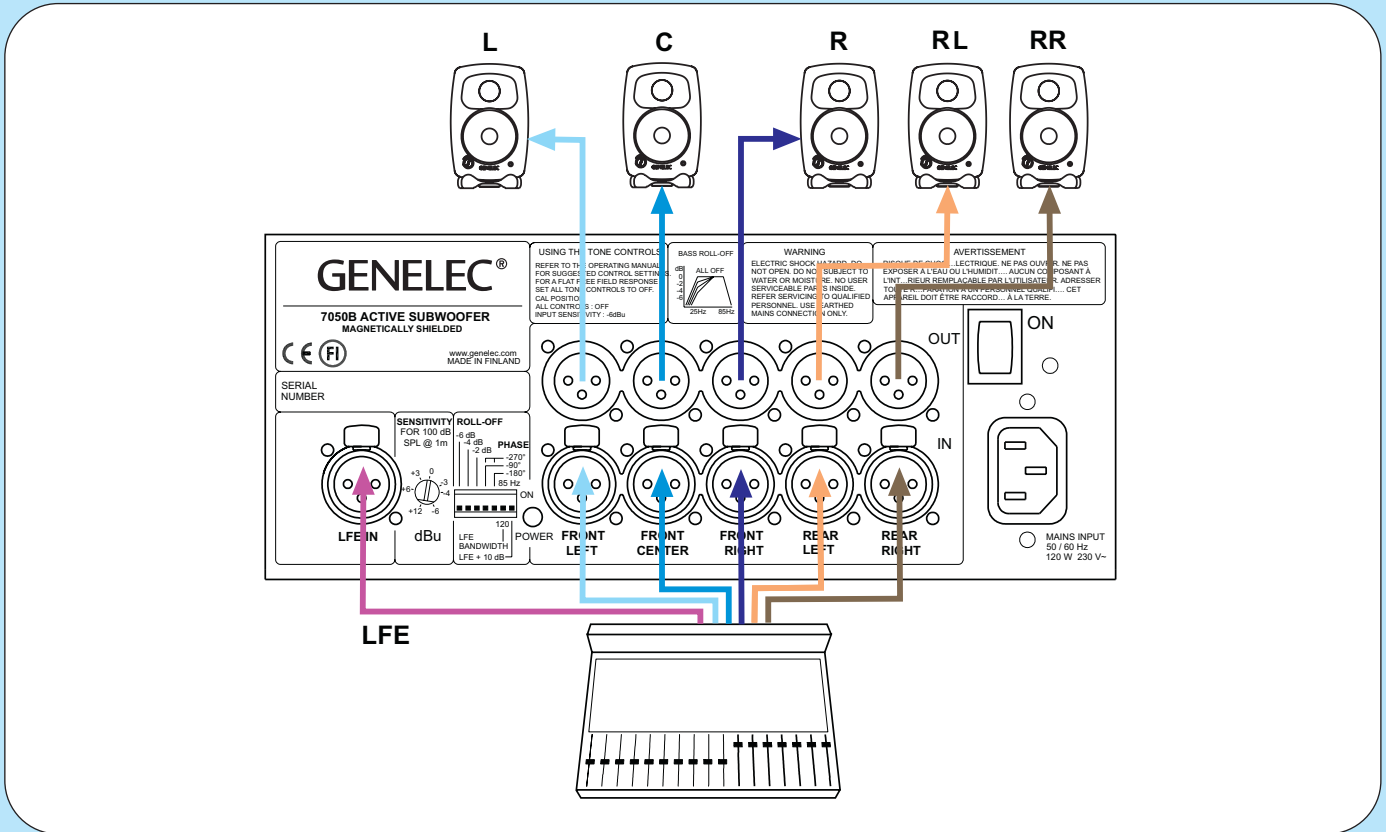

Setting the LFE channel reproduction bandwidth

LFE channel reproduced up to 85 Hz

85 Hz
Subwoofer

LFE channel reproduced up to 120 Hz

120 Hz
Subwoofer

Phase alignment

1. Connect a loudspeaker to the "FRONT CENTER" output of the subwoofer and feed an 85 Hz test signal to the "FRONT CENTER" input
2. Toggle the subwoofer's dip switch 5 "on" and "off" and set it to the position which gives the lowest sound level at the listening position.
3. Toggle the subwoofer's dip switch 4 "on" and "off" and set it to the position which gives the lowest sound level at the listening position.
4. Set dip switch 5 to the opposite setting.